

Reg. No. :

**Question Paper Code : 10420**

B.E./B.Tech. DEGREE EXAMINATION, MAY/JUNE 2012.

Fifth Semester

Mechanical Engineering

ME 2305/ME 55/ME 1305 /10122 ME 506 — APPLIED HYDRAULICS AND PNEUMATICS

(Common to 080120027 – Hydraulics and Pneumatics Systems)

(Regulation 2008)

Time : Three hours

Maximum : 100 marks

Answer ALL questions.

PART A — (10 × 2 = 20 marks)

1. Compare hydraulic and pneumatic drives for automation.
2. State Pascal's law with an industrial example.
3. What are positive displacement pumps?
4. Mention the significance of a telescopic cylinder with an industrial example.
5. Identify the following elements represented in Fig.1 and Fig.2.



Fig. 1

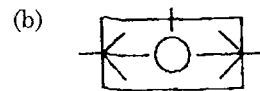

Fig. 2

6. List any four basic types of electric switches used in electrically controlled fluid power circuits.
7. 'Quick exhaust valve is used to increase the piston speed of spring return single-acting pneumatic cylinder' – Justify.
8. State any four advantages of pneumo – hydraulic circuits.
9. List the three types of proportional control valves.
10. State any four common causes for hydraulic system breakdowns.

## PART B — (5 × 16 = 80 marks)

11. (a) (i) Explain in detail any eight desirable properties of a good hydraulic fluid. (12)
- (ii) Explain the advantages and limitations of using petroleum based hydraulic oils. (4)

Or

- (b) (i) Hydraulic oil of kinematic viscosity 0.9 stokes, flows through a 35 mm diameter pipe at a velocity of 4 m/s for a length of 100 m. Find the head loss due to friction (in units of bar). Assume specific gravity of oil as 0.90. (8)
- (ii) State the significance of 'K-factor' in determining the losses in valves and fittings. Determine the head loss (in units of bar) across a 40 mm wide open gate valve, when hydraulic oil of specific gravity 0.9 flows through it at a rate of 0.015 m<sup>3</sup>/s. The K-factor for wide open gate valve is 0.19. (8)
12. (a) (i) With a neat sketch, explain the construction and working principle of an external Gear pump. (10)
- (ii) A pump having a displacement of 80cm<sup>3</sup>, delivers oil at the rate of 1.25 lps at 1200 rpm and 75 bar. If the prime mover input torque is 90 Nm, calculate the overall efficiency of the pump and the theoretical torque required to operate the pump. (6)

Or

- (b) (i) With a neat sketch, explain the construction and cushioning mechanism in a cylinder. (8)
- (ii) With a neat sketch, explain the working principle of balanced Vane pump. (8)
13. (a) Write short notes on:
- (i) Direct acting pressure reducing valve
- (ii) Pilot operated sequence valve. (8 + 8)

Or

- (b) (i) List the advantages and limitations of a spring loaded accumulator. (4)
- (ii) A pump/accumulator power pack is to supply the fluid flow demanded by a hydraulic system as shown in Fig.3. The system working pressure is 125 bar and the maximum pressure at the accumulator is 200 bar. Assuming the accumulator precharge pressure is 90% of its maximum working pressure, determine

- (1) the actual pump delivery required
- (2) the maximum volume of fluid to be stored in the accumulator
- (3) the accumulator volume assuming an isothermal charge and discharge of the accumulator. (12)

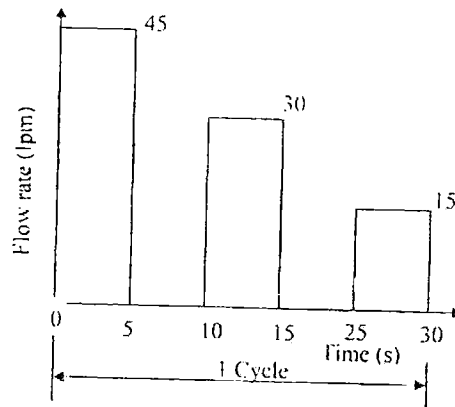

Fig. 3

14. (a) (i) With a neat sketch, explain the working principle of a Screw compressor. (8)
- (ii) With neat sketches, explain the importance of a filter and regulator unit in a pneumatic system. (8)

Or

- (b) Valve bodies are to be marked with the letters P, A, B and R (Fig.4). The valve bodies are placed in the holder manually. Stamping cylinder A stamps the letter in the body and returns. Cylinder B pushes the parts from the holder into a basket and returns to its initial position. Design a pneumatic sequential circuit for the above operation using cascade method. (16)

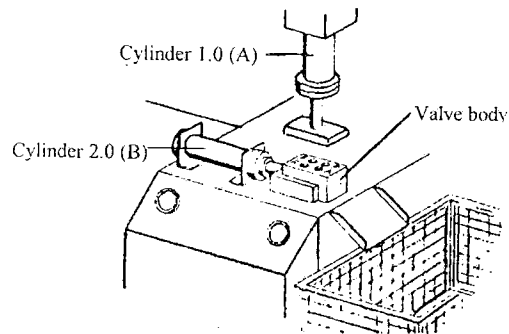
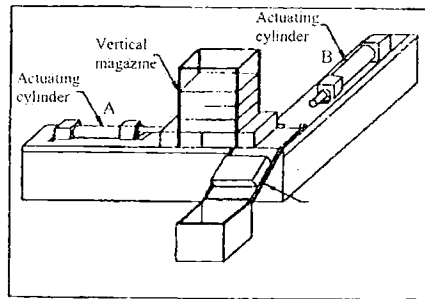

Fig. 4

15. (a) (i) Explain the hydromechanical servo valve with an industrial example. (8)  
 (ii) Write short notes on Bistable Flip-Flops. (8)

Or

- (b) (i) Two pneumatic cylinders are used to transfer parts from a magazine onto a chute (Fig.5). When a pushbutton is pressed, cylinder (A) extends, pushing the part from the magazine and positions it in preparation for transfer by cylinder (B) onto the outfeed chute. Once the part is transferred, the cylinder (A) retracts, followed by the cylinder (B). Sketch the ladder logic diagram for the above operation. (10)



Configuration of transfer station.

Fig. 5

- (ii) With a block diagram, explain the major units of a PLC. (6)