

Reg. No. :

--	--	--	--	--	--	--	--	--	--	--	--	--	--	--	--	--	--	--	--

Question Paper Code : C 1315

B.E./B.Tech. DEGREE EXAMINATION, APRIL/MAY 2010.

First Semester

Civil Engineering

GE 1101 – ENGINEERING GRAPHICS

(Common to all Branches)

(Regulation 2004)

Time : Three hours

Maximum : 100 marks

Answer all FIVE questions in A3 size drawing sheet book provided.

Use appropriate scale if necessary, to fit the solution within A3 size.

(5 × 20 = 100)

1. (a) (i) A point B is 30 mm in front of V.P. and 20 mm above H.P. Draw the projections of the point.
- (ii) A line LM 70 mm long, has its end L 10 mm above H.P and 15 mm in front of V.P. Its top and front views measure 60 mm and 40 mm respectively. Draw the projections of the straight line and find its inclinations with HP and VP.

Or

- (b) A thin rectangular plate of side 40 mm × 20 mm has its shorter side in the HP and inclined at an angle of 30° to the VP. Project its front view when its top view is a perfect square of 20 mm side.
2. (a) A pentagonal prism, side of base 25 mm and axis 50 mm long, rests with one of its edges on H.P. such that the base containing that edge makes an angle of 30° to H.P and its axis is parallel to V.P. Draw its projections.

Or

- (b) A hexagonal pyramid, side of base 25 mm and axis 50 mm long, rests with one of the edges of its base on HP and its axis is inclined at 30° to HP and parallel to VP. Draw its projections.

3. (a) A square prism, side of base 30 mm and axis 60 mm long, rests with its base on HP and one of its rectangular faces is inclined at 30° to VP. A section plane perpendicular to VP and inclined at 60° to HP cuts the axis of the prism at a point 20 mm from its top end. Draw the sectional top view and true shape of section.

Or

- (b) A hexagonal prism, edge of base 20 mm and axis 50 mm long, rests with its base on HP such that one of its rectangular faces is parallel to VP. It is cut by a plane perpendicular to VP, inclined at 45° to HP and passing through the right corner of the top surface of the prism. Draw the development of the lateral surface of the truncated prism.
4. (a) Draw the isometric projection of a sphere of diameter 50mm resting centrally on the top of a cube of side 60 mm.

Or

- (b) A square prism, sides of base 40 mm and height 60 mm, rests with its base on the ground such that one of its rectangular faces is parallel to and 10 mm behind the picture plane. The station point is 30 mm in front of PP, 80 mm above the ground plane and lies in a central plane 45 mm to the right of The centre of the prism. Draw the perspective projection of the square prism.
5. (a) Draw the front , top and right side views of the object shown in Fig. 1

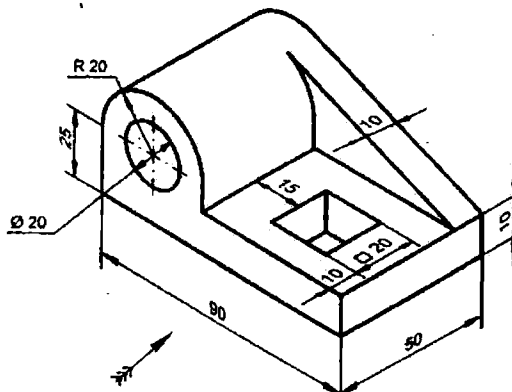

Fig.1.

Or

(b) Draw the front, top and right side views of the object shown in Fig.2.

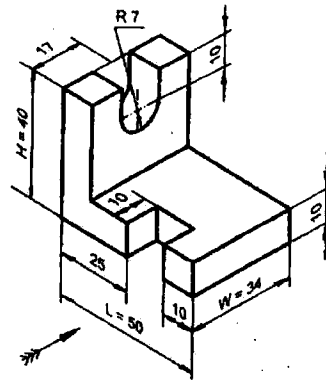

Fig.2.

(All dimensions are in mm)
